

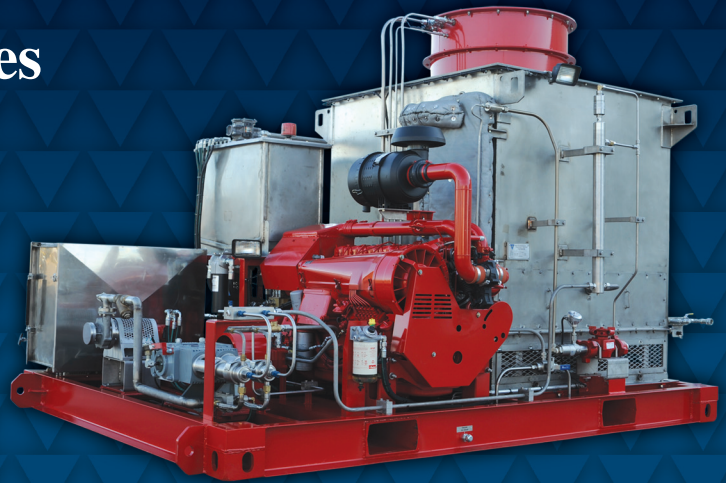

CS&P Technologies



Coiled Tubing Reel Purging Skid

Our compact unit is a low cost solution for purging coiled tubing reels. The industry has historically used larger units and now our smaller unit does the job better at a lower cost.

As with all of our units, the attention to detail ensures a properly designed system that lowers operating cost and maintenance making it the most reliable in the industry.

18119 Telge Road • Cypress, Texas 77429
Office (713) 467-0869 • Fax (713) 464-2089
www.csphouston.com

FEATURES

- Cost effective alternative to high rate units
- Allows maximum utilization of existing nitrogen fleet
- Designed for use in multiple pumping applications
- Minimal operating cost
- Simple operation
- Low maintenance design
- Compact design allows versatility in packaging

PERFORMANCE SPECIFICATIONS

- Fluids Pumped: Nitrogen
- Maximum Flow Rate: 650 SCFM (7 GPM)
- Continuous Working Pressure: 3,600 PSI (6,000 PSI MAWP)

CS&P MANUFACTURED NITROGEN COMPONENTS

Duplex Pump

- 2-ICP-100 with 1.25" Cold Ends

Centrifugal Pump

- 1" x 2" x 4.5" Mechanical Seal or "Sealless" Magnetic Drive Option

Vaporizer

- 40,000 SCFH Continuous Duty Forced Air Ambient Vaporizer

Coiled Tubing Reel Purging Skid

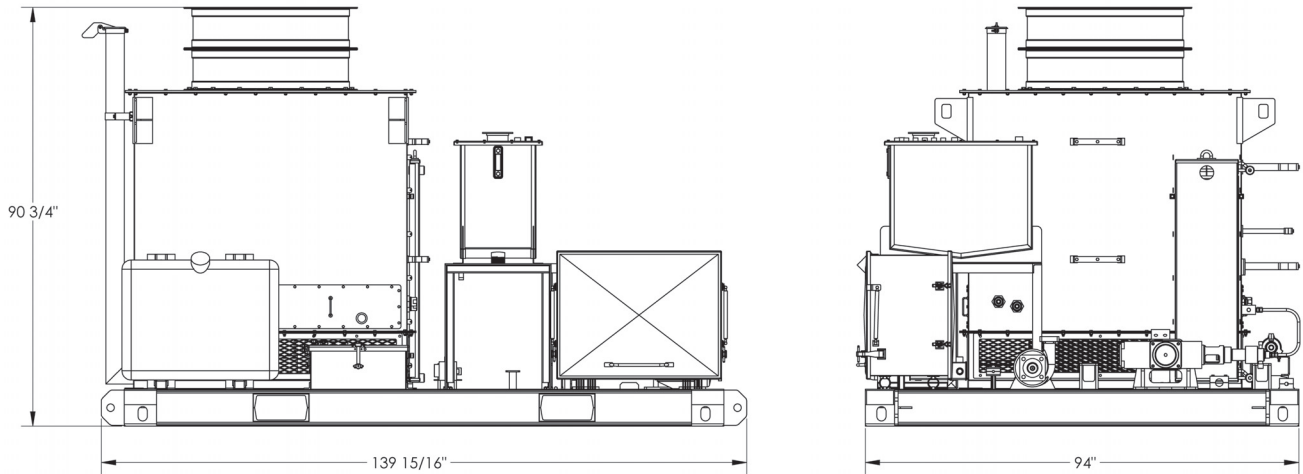

APPROX WEIGHT: 9,500 LBS

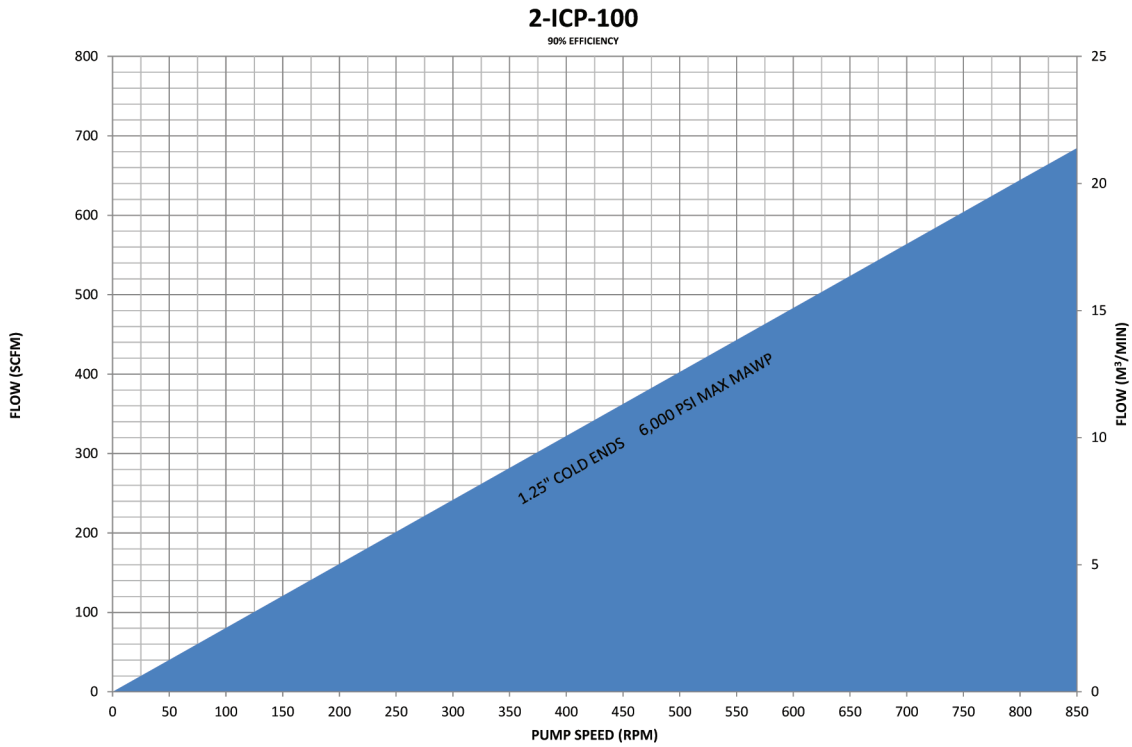

CS&P Technologies

18119 Telge Road • Cypress, Texas 77429
Office (713) 467-0869 • Fax (713) 464-2089
www.csphouston.com