

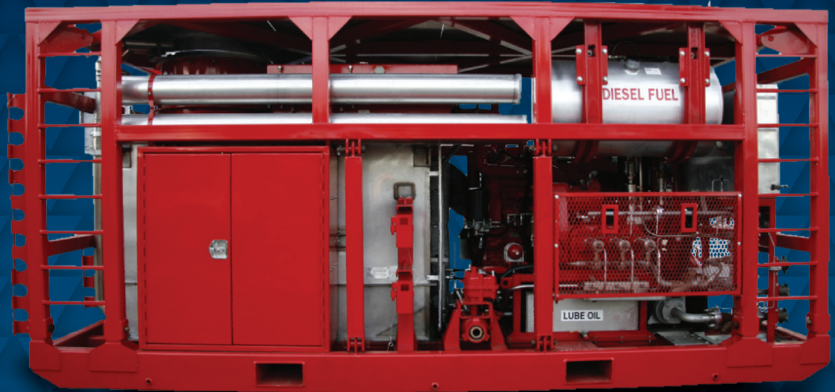

**CS&P Technologies**



## **180,000 SCFH Nitrogen Skid**

*CS&P's 180,000 SCFH Nitrogen Skid is the industry leader in performance and efficiency. Attention to detail and quality manufacturing ensure your satisfaction with our products.*

*CS&P's ultra efficient vaporization system ensures maximum heating of the nitrogen using minimum HP. Our advanced technology lowers operating cost and maintenance making our unit the most reliable in the industry.*

*Each unit is designed and manufactured to operate at maximum rated capacity, everyday.*

18119 Telge Road • Cypress, Texas 77429  
Office (713) 467-0869 • Fax (713) 464-2089  
[www.csphouston.com](http://www.csphouston.com)

### **FEATURES**

- Removable roof and frame
- Designed for ease of operation and maintenance

### **PERFORMANCE SPECIFICATIONS**

- Fluids Pumped: Nitrogen
- Maximum Flow Rate: 3,000 SCFM (32 GPM)
- Maximum Working Pressure: 10,000 PSI with option for 15,000 PSI

### **CS&P MANUFACTURED NITROGEN COMPONENTS**

#### **Triplex Pump**

- 3-ICP-200 with Integral Gear Reduction Box
- 1.625" or 1.25" Cold Ends

#### **Centrifugal Pump**

- 1.5" x 2.5" x 6" Mechanical Seal or "Sealless" Magnetic Drive Option

#### **Vaporizer**

- 180,000 SCFH Forced Air Ambient Vaporizer

# 180,000 SCFH Nitrogen Skid

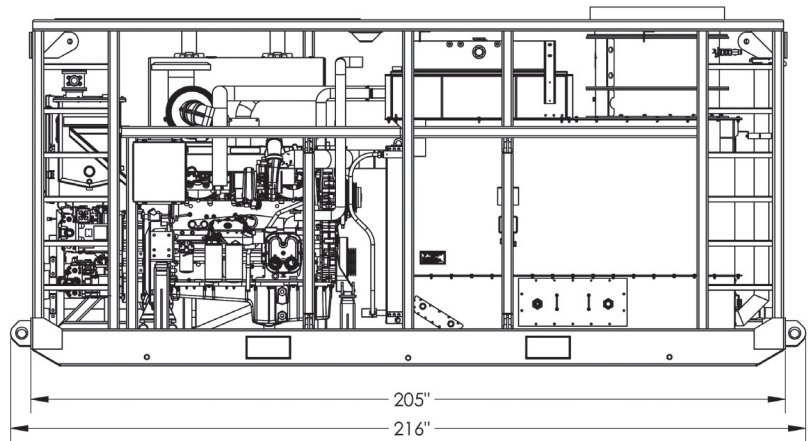
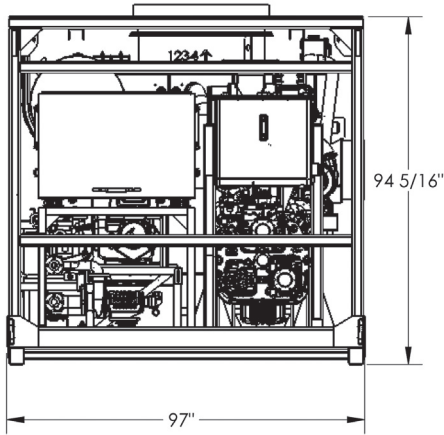

APPROX WEIGHT: 23,600 LBS

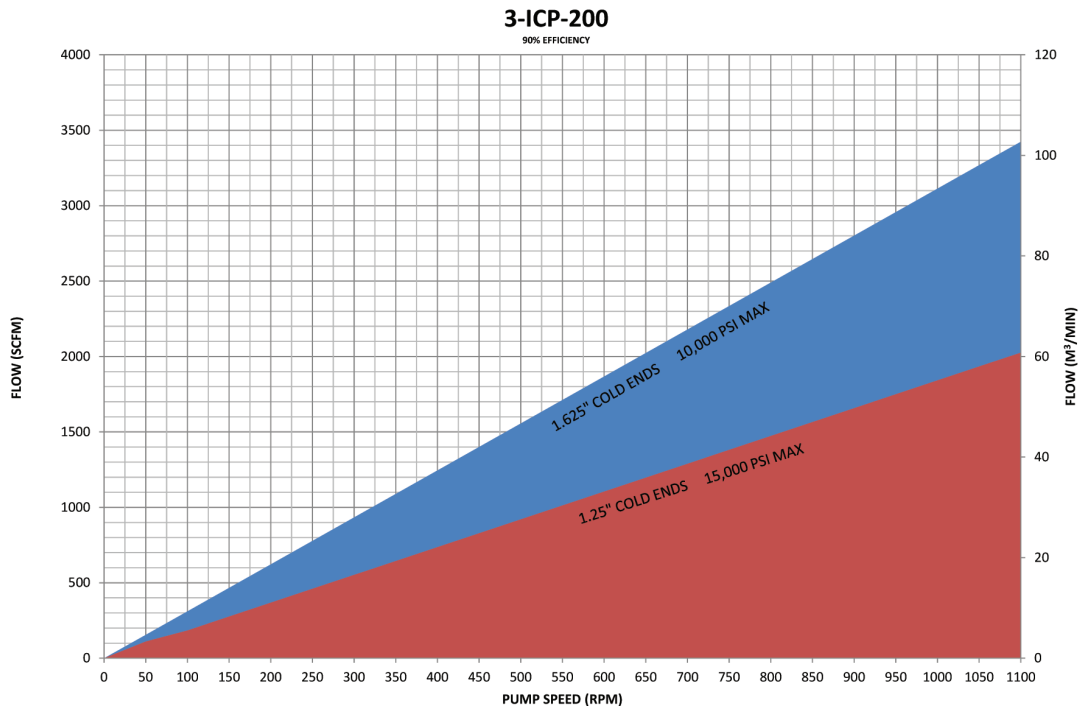

**CS&P Technologies**

18119 Telge Road • Cypress, Texas 77429  
Office (713) 467-0869 • Fax (713) 464-2089  
[www.csphouston.com](http://www.csphouston.com)