

## LEVER CHAIN HOIST **MODEL: LH**

### FEATURES:

- Standard overload clutch
- Double pawl Weston style load brake
- Fully machined steel load sheaves
- Cast steel hook latches
- Fully enclosed gear train and caged internal bearings
- All exposed parts plated or powder coated for corrosion protection
- Double pawl Weston style load brake
- Conforms to ASME B30.16 - Chain Hoists and Standard B30.21 - Lever Hoists

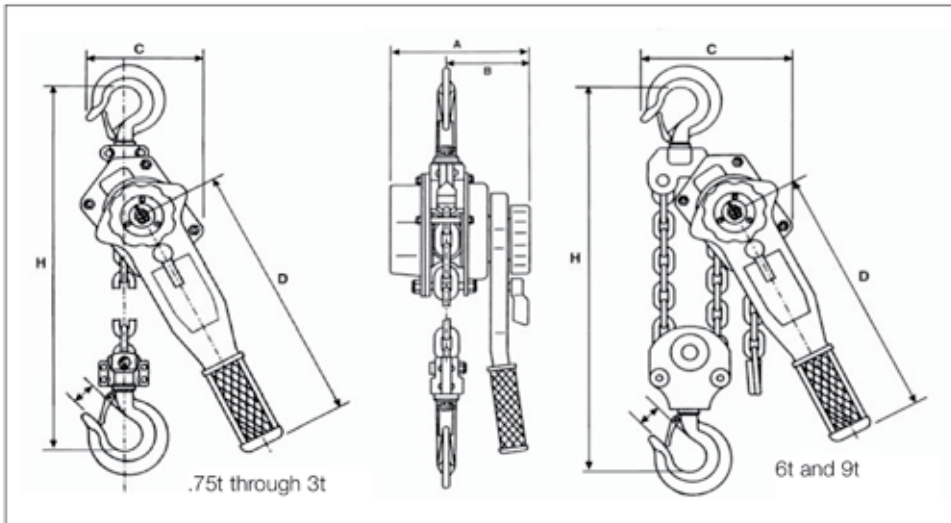

Model	Working Load Limit	Effort to Lift Rated Load (lbs.)	Net Weight with 10 ft Lift (lbs.)	Chain Size	Falls of Chain	Dimensions (inches)					Hook Openings
						A	B	C	D	H	
TUF-LH075	.75 t	30.86	16	6	1	5.83	3.55	5.36	11.03	12.8	0.87
TUF-LH150	1.5 t	48.49	25	8	1	6.78	3.86	6.3	16.15	14.97	1.26
TUF-LH300	3 t	70.53	47	10	1	7.88	4.53	7.09	16.15	18.91	1.46
TUF-LH600	6 t	74.94	69	10	2	7.88	4.53	9.26	16.15	24.43	1.77
TUF-LH900	9 t	79.2	103.4	10	3	7.88	4.53	12.44	16.15	27.56	2.36

**NOTE:** Please specify chain length required when ordering, by adding a -5, -10, -15, -20 to the end of model number.